

Kubernetes networking in the telco space

LFN Developer Forum

Gergely Csatari (using the materials of Robert Springer, and Peter Megyesi with the help of Levente Kale, Laszo Janosi and Gergo Huszty)

26-03-2018

Whoami:

Gergely Csatari

Nokia

gergely.csatari@nokia.com

csatari on freenode

@GergelyCsatari on Twitter



A wide-angle photograph of a snowy mountain landscape. The terrain is covered in deep, white snow, with gentle slopes and ridges. Several hikers are visible, scattered across the scene, some standing and others in motion. A distinct path of footprints winds through the snow, leading from the foreground towards the middle ground. The lighting is soft, suggesting an overcast day, and the overall atmosphere is serene and quiet.

Basic overview of Kubernetes networking

Most prominent CNI plugins

Features important for Telcos

Solutions

Kubernetes networking basics

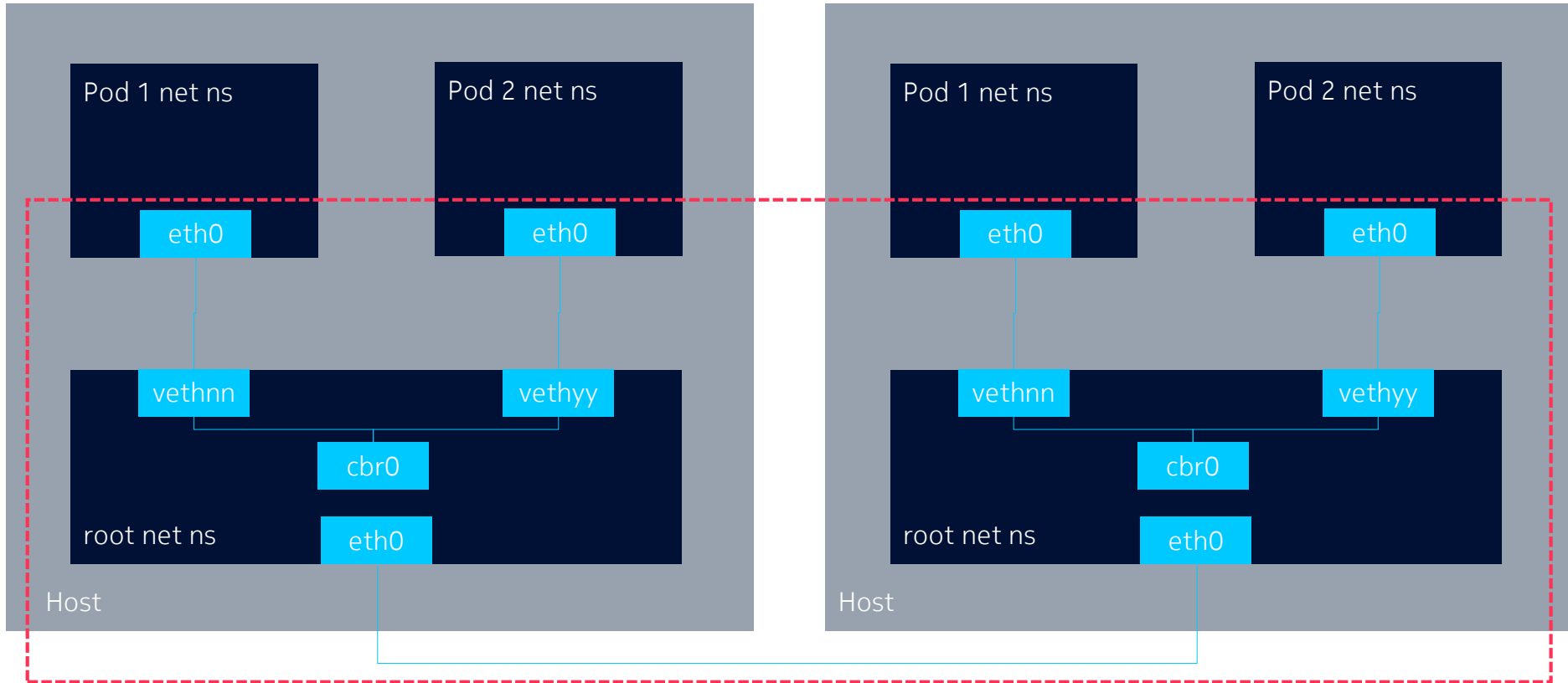

Kubernetes networking basics

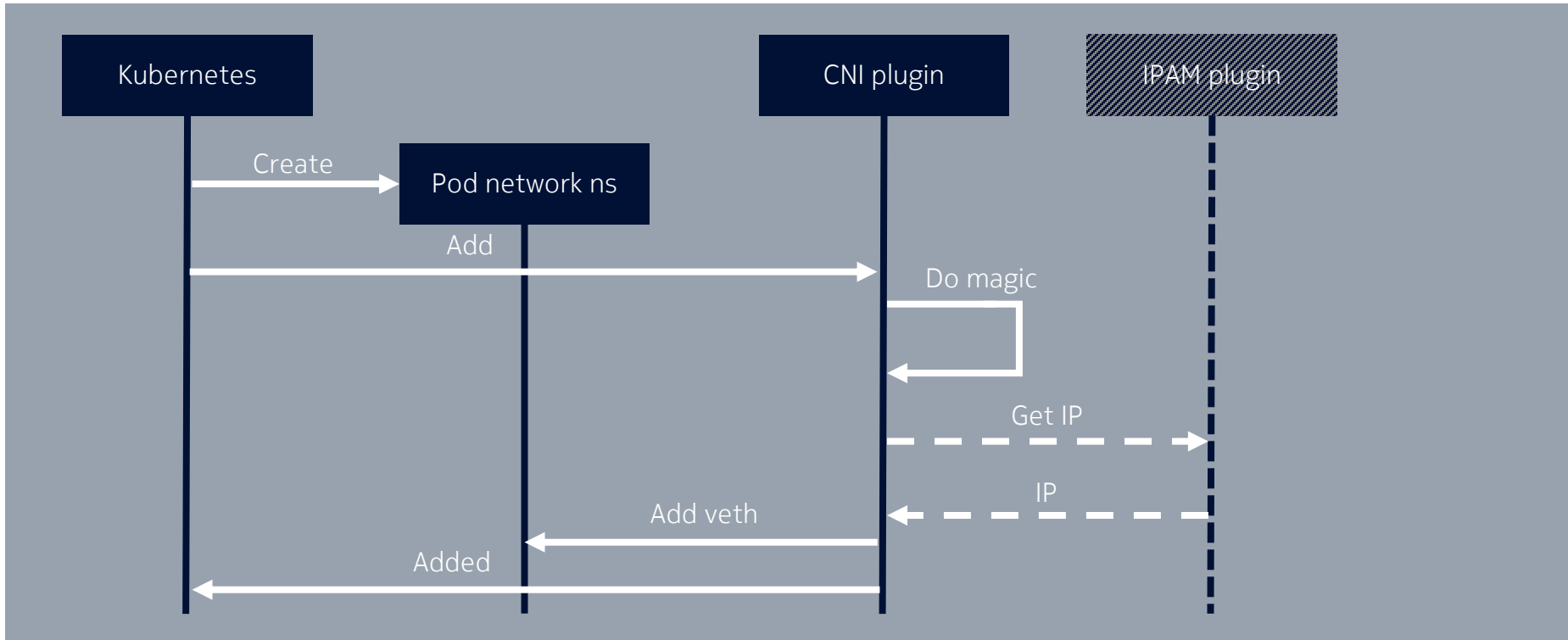

Kubernetes networking basics

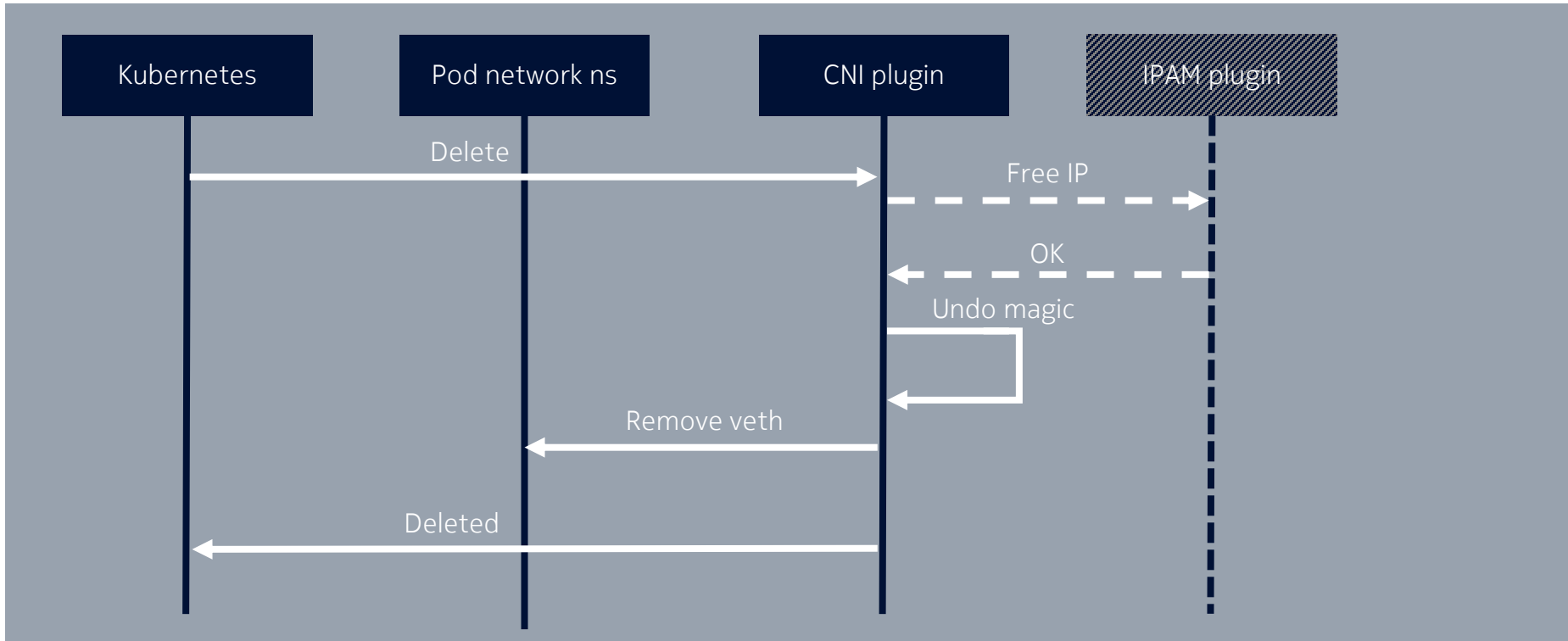

Most relevant reference CNI plugins

bridge

Creates a bridge, adds the host and the container to it.

ipvlan

Creates a new IP address on the host interface, forwards all traffic of that to the container.

macvlan

Creates a new MAC address, forwards all traffic of that to the container.

dhcp

Runs a daemon on the host to make DHCP requests on behalf of the container.

Most relevant CNI plugins for production



Uses VXLAN tunnels between the hosts using a kernel implementation. Flannel uses etcd to store metadata.



Provides integration to Calico which defines BGP agents and advertises the pod subnets to the fabric.



Provides integration to Nuage, the highly scalable policy-based Software-Defined Networking (SDN) platform. Nuage uses the open source Open vSwitch for the data plane along with a feature rich SDN Controller built on open standards.



An overlay based generic networking solution for containers.



A CNI plugin to cascade other CNI plugins.

Things what our telco workload misses from these
Support for multiple interfaces

What? Some pods should have two or more interfaces.

Why? Support for load balancers for telco protocols, SCTP MH, separation of different traffic types.

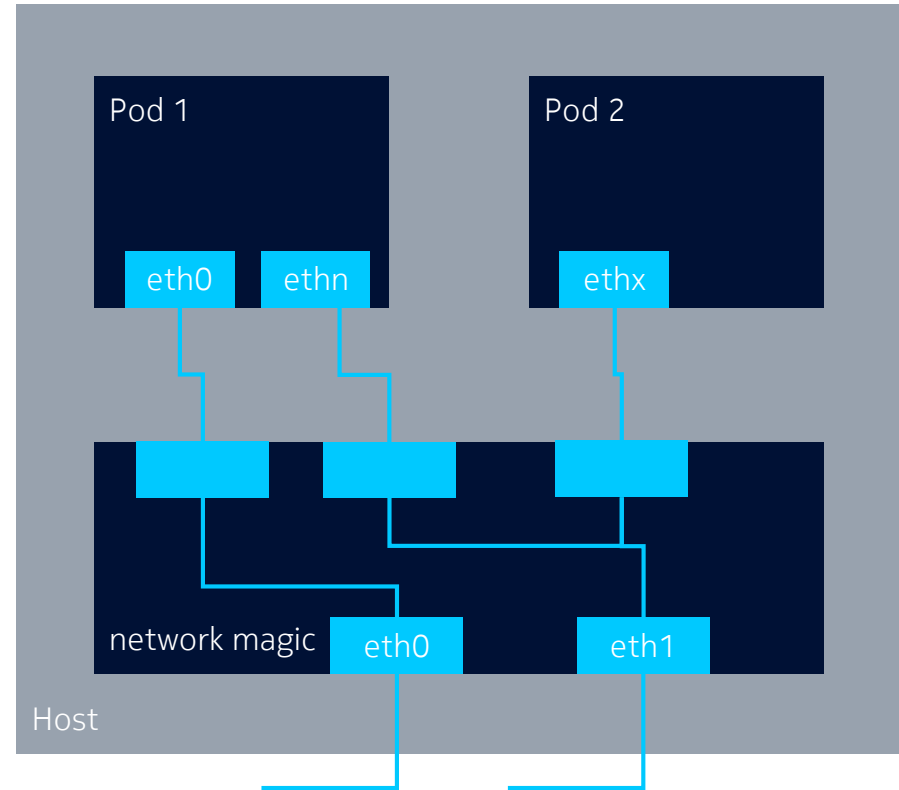

Things what our telco workload misses from these
Fixed IP address

What? It should be possible to manually set the IP address of some pods.

Why? These are well known IP addresses distributed in configuration..

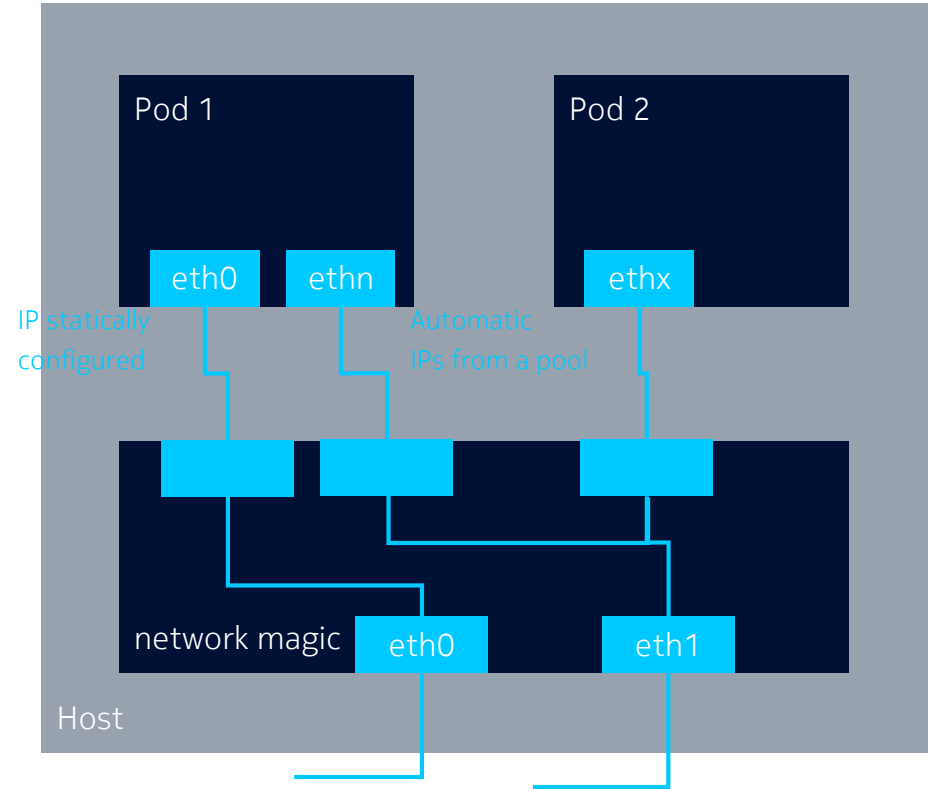

Things what our telco workload misses from these Overlay and NAT less

What? There should be no overlay used to implement the host-to-host communication and there should be no NAT used in the hosts.

Why? Both NAT-ting and overlay networks introduce extra latency into packet handling. For radio handling applications a ms delay can be serious. There are protocols which can not be used together with NAT.

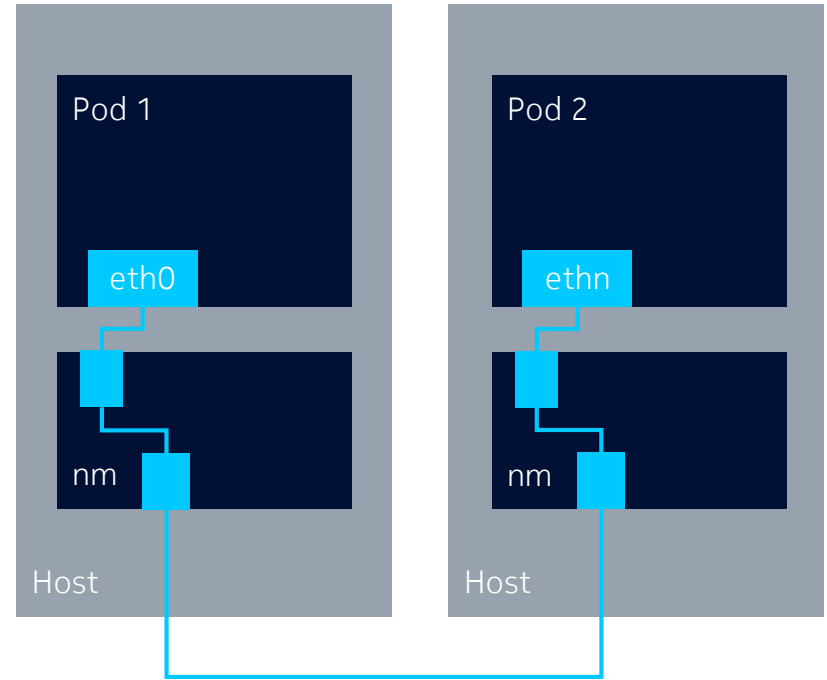

Things what our telco workload misses from these SR-IOV support

What? The CNI plugin should be able to utilize SR-IOV capabilities of the host if there are any. This should be possible without NIC vendor lock in.

Why? SR-IOV makes packet processing faster and in telco we need fast packet processing.

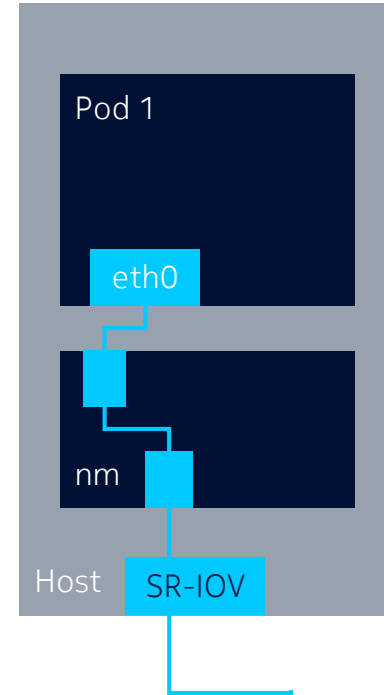

Things what our telco workload misses from these DPDK

What? The CNI plugin should be able to utilize the DPDK capabilities of the host if there are any.

Why? DPDK makes packet processing faster and in telco we need fast packet processing.

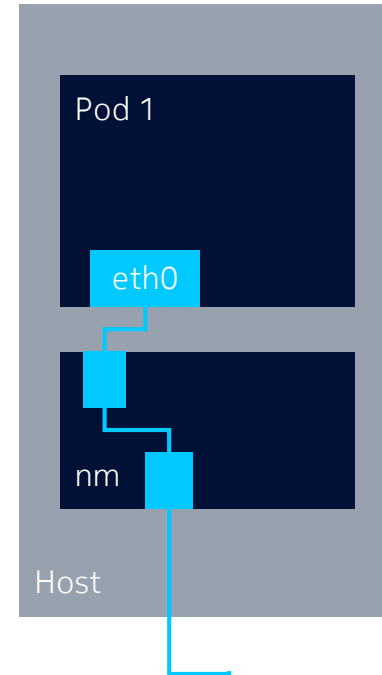

Things what our telco workload misses from these Cloud compliancy

What? The CNI networking solution should not state any special networking requirements to the underlying cloud infrastructure in case of Kubernetes is running on top of VM-s of a cloud infra.

Why? Our solutions are deployed to both VM based clouds and to bare metal and we would like to support both of them using the same software stack.

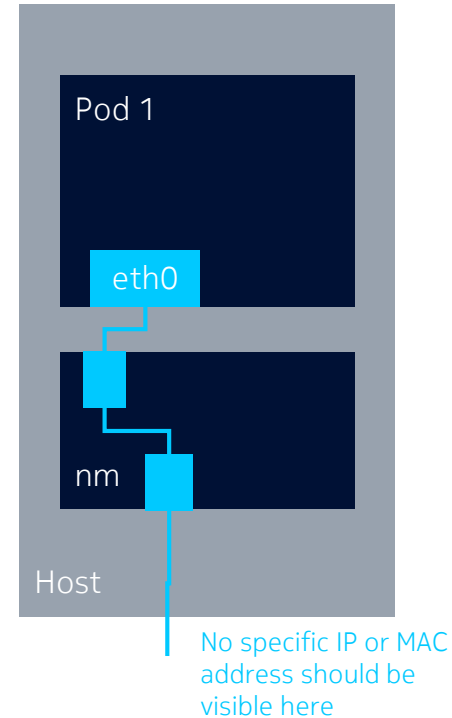

Things what our telco workload misses from these Firewall or network policy support

What? The CNI plugin should support explicit firewall rules, static and policy based routing to control the traffic between the different pods.

Why? There should be a way to control the traffic between the pods.

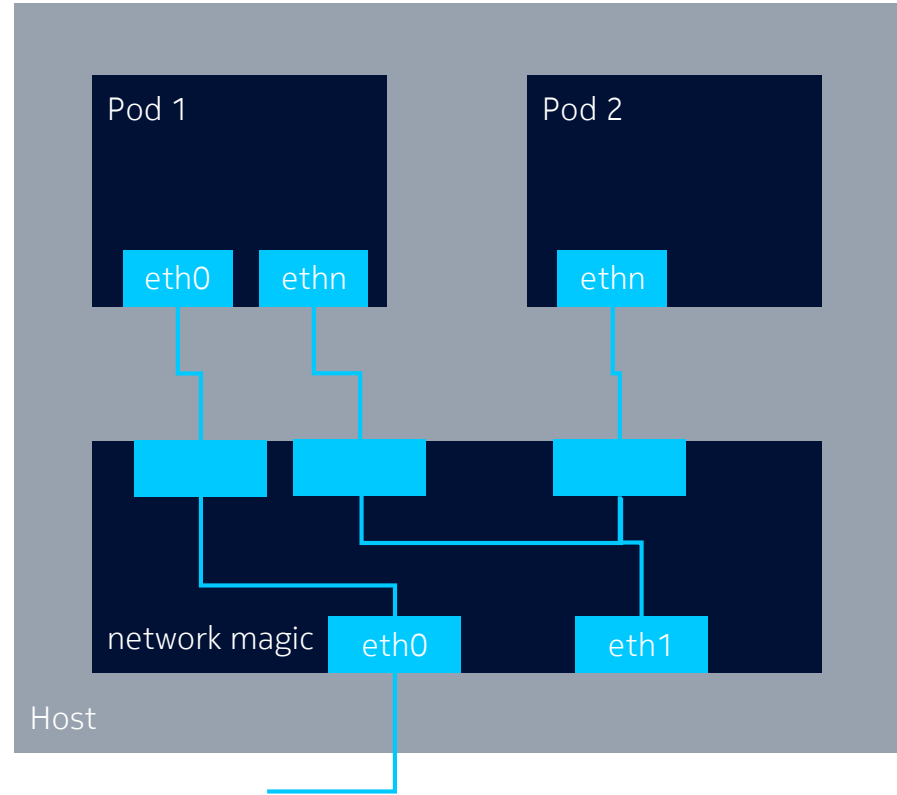

Solutions

Multiple interfaces There are several discussions in [kubernetes-sig-network](#) and there are concrete plans [for 2018](#). Intel's Multus provides a solution to cascade different CNI plugins.

SR-IOV and DPDK There is an [CNI plugin](#) for DPDK with SR-IOV support. There is a [vhostuser](#) CNI plugin which can support DPDK accelerated OvS or VPP.

Network policies Calico can be run in policy enforcement mode what is also called [Canal](#).

Solutions

Nokia danm

Originally it was built as part of the container infrastructure of one Nokia VNF.

Uses ipvlan for network segregation. There is no overlay or NAT.

Supports both VLAN and VxLAN interfaces.

Can cascade other CNI plugins, this is used for SR-IOV.

Has its own ipam plugin which supports fixed IP-s and IP routes.

Works based on the annotations in the pod manifest.

Solutions

Nokia danm example

IP a&b – These IPs are created without VLAN and mapped to Pods 1&2.

IP c&d – These IPs are created with VLAN ID. The VLAN tagging happens on the Host side.

IP e&f – These IPs are created with different VLAN IDs and placed on different NICs. This mode is useful for SCTP traffic.

IP g&h&i – These IPs are created with VXLAN (not simple VLAN) and placed above a team interface which provides redundancy. This mode is useful for container internal traffic.

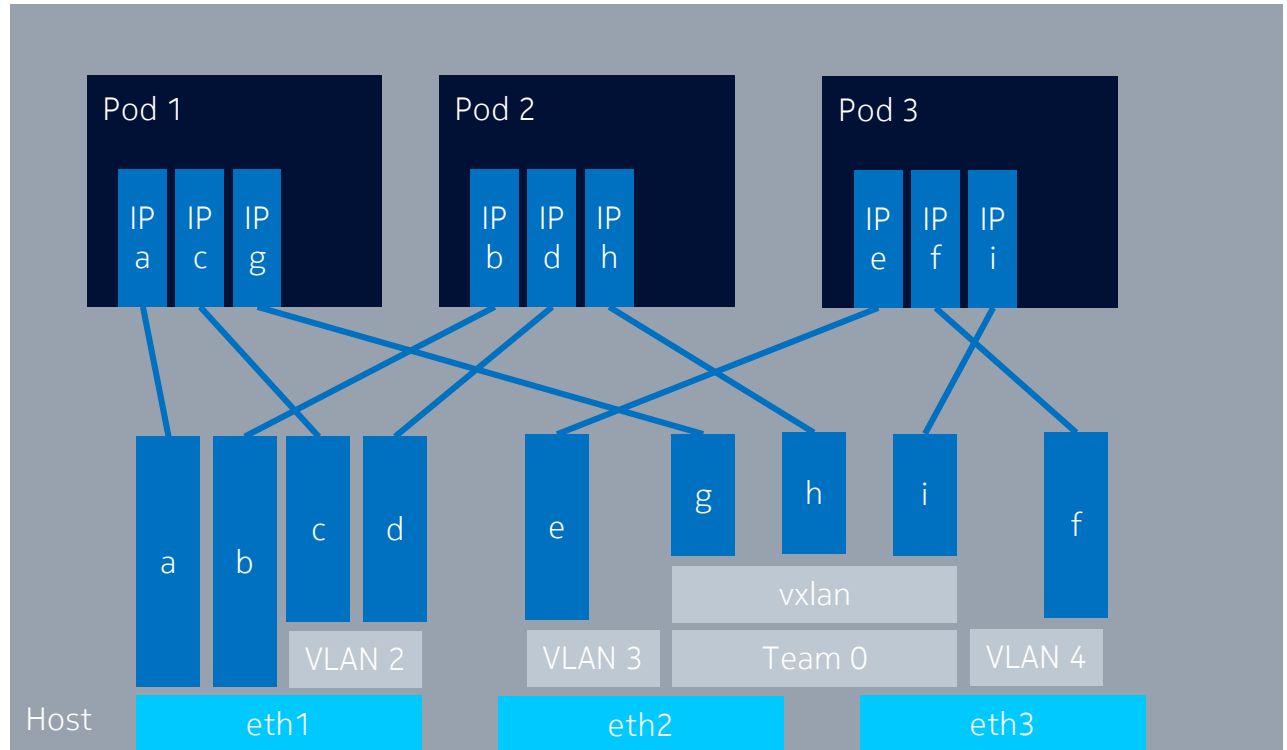

Q&A

NOKIA

References

1. <https://kubernetes.io/docs/concepts/cluster-administration/networking/>
2. <https://medium.com/@ApsOps/an-illustrated-guide-to-kubernetes-networking-part-1-d1ede3322727>
3. <https://medium.com/@ApsOps/an-illustrated-guide-to-kubernetes-networking-part-2-13fdc6c4e24c>
4. <https://github.com/container networking/plugins>